

Tumble dryer

T5130, T5130C

Features and benefits

- **Compass Pro[®] microprocessor offers:**
 - Large display and one control knob for easy program selection
 - Language selection
 - Quick start and option buttons for frequently used programs
 - Drying program packages optimized for Economy, Care and Time
 - Service program for adjustment of parameters
 - USB connection
- Residual Moisture Control for an accurate drying result and a low energy consumption
- Reversing drum for less tangling of large items
- Stainless steel drum
- Reversible door hanging for a convenient laundry flow
- Easy access to vital parts from the top and rear for simple servicing
- The coin version with Ecopower to avoid over drying of the garments and get a lower energy consumption
- T5130C: For optimal performance the room temperature should not exceed 25° Celcius



Images shown are a representation of the product only and variations may occur.

Main options

- Stainless steel front
- Connection to booking- /payment- system or coin meter
- Stacking frame for mounting T5130 on top of W555H
- Stainless steel base frame
- Integrated condense system

Main specifications			T5130	T5130C
Rated capacity,	filling factor 1:22	kg/lb	6/13	6/13
Drum volume		litre	130	130
Drum diameter		mm	575	575
Heating alternatives				
electric		kW	5.1 / 3.2	3.0
Consumption data*				
Total time full load		min	32	55
Energy consumption full load		kWh	2.78	2.96
Evaporation		g/min	92.8	48
Energy kWh/litre water evaporated		kWh/l	0.94	1.00
* At rated capacity 100% cotton load at 50% initial moisture dried to 0%.				

Electrical connections*					
Heating alternative	Main voltage	Hz	Heating power kW	Total power kW	Recommended fuse A
T5130	240V 1 -	50/60	3.2	3.5	16
	220-230V 3 -	50/60	3.1	3.3	16
	240V 3 -	50/60	3.2	3.5	16
	220-230V 3 -	50/60	4.9	5.1	16
	240V 3 -	50/60	5.1	5.4	16
	380-400V 3 -	50/60	4.9	5.1	10
	415V 3 -	50/60	5.1	5.3	10
	440V 3 -	60	5.1	5.4	10
	480V 3 -	60	5.1	5.3	10
T5130C	380-400V 3N -	50/60	4.9	5.1	10
	440V 3 -	60	3.0	3.4	10
	380-400V 3N -	50/60	3.0	3.3	10
	220-230V 3 -	50/60	2.9	3.3	10

Connections		T5130	T5130C
Air outlet	mm	∅ 100	-
Maximum air flow	m ³ /h	240	-
Condensate		-	1/2"
Maximum static back pressure	Pa	80	-
Sound levels			
Airborne sound level	dB(A)	<70	<70
Heat emission			
% of installed power, max		15	15
Shipping data**			
Shipping volume	net, kg m ³	58 0.51	57 0.63
Accessories			
Stacking frame for mounting T5130 on top of W555H		x	x
Stainless steel base frame		x	x
Dimensions in mm			
A Width		597	597
B Depth		725	725
C Height		839	839
D		138	138
E		50	50
F		89	89
G		200	200
1 Operating panel 2 Door opening ∅ 370 mm 3 Electrical connection 4 Exhaust connection 5 Condense connection			

* Other voltages available, see installation manual.

** Average data. Crated weight/shipping volume depends on configuration. Please contact logistics for exact measures.

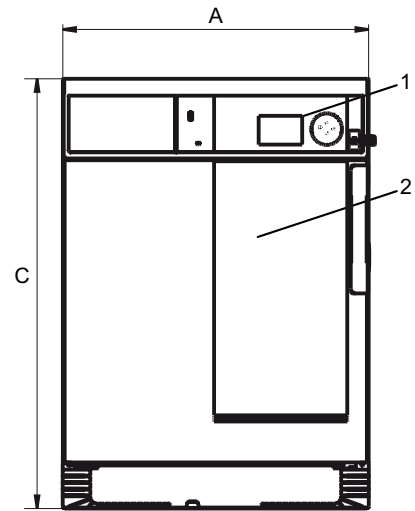

Front

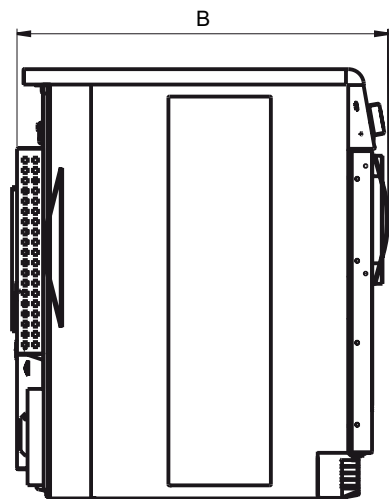

Left side

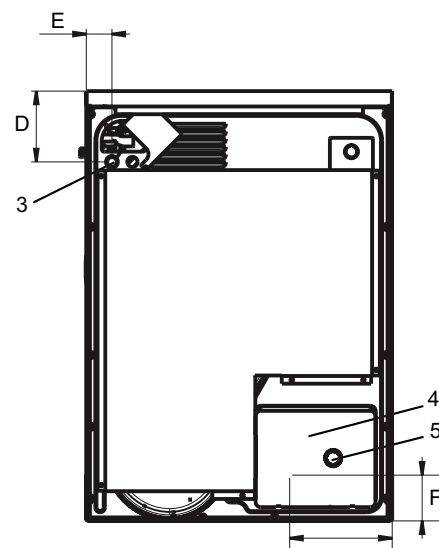

Rear side