

Washer extractor

W4400H

Features and benefits

- Clarus Control® – programmable microprocessor with 9 fixed and up to 192 programs to allow free programming
- High extraction for efficient dewatering
- Frequency-controlled motor for optimal washing
- Supplied with 8 + 5 signals for liquid detergents
- Eight connections for liquid detergents
- Large door opening for easy loading and unloading
- All critical parts made from stainless steel to provide a high level of corrosion resistance
- Powder painted galvanised steel side panels
- Bearing seals lubricated with oil to ensure a long service life. Empty container alarm
- Electric or direct steam heating
- Low noise level for pleasant working environment
- Designed for easy servicing and maintenance

Main options

- Front mounted loading hopper
- Forward or forward/backward tilting with full reversing function
- Noise/heat insulation
- Test tap with level tube
- Two drain valves for recovering water/wash solution
- Five-compartment detergent box for powder detergent (located at the front or on the right hand side of the machine)
- Third water valve
- Large water valves
- IS – Integrated Saving
- Connection for intelligent detergent system (DMIS)
- Connection to CMIS



Images shown are a representation of the product only and variations may occur.

Main specifications				W4400H	
Max. capacity		kg/lb	45/100		
Drum, volume		litre	400		
	diameter	ø mm	920		
Extraction		rpm	825		
G-factor			350		
Heating alternatives	electricity	kW	36.0 / 32.8		
	steam		x		
	hot water		x		
Consumption data "Normal 60°C" * (7G01)				El	Steam
Total time (cold+hot/cold)		min	43/-	38/41	
Water consumption (cold/hot)		litre	501/80	497/72	
Energy consumption (motor/heating)		kWh	1.1/4.1	1.1/-	
Steam consumption (cold/hot)		kg	-	6.1	
Steam consumption (cold)		kg	-	12	
* Water temperature 15°C cold water and 65°C hot water.					
** Steam at 300-400 kPa.					

Electrical connections					
Heating alternative	Main voltage		Heating power kW	Total power kW	Recommended fuse A
		Hz			
Electric heated	220-240V 3 ~	50/60	36.0	38.0	100
	380-415V 3 ~	50/60	32.8	34.8	63
	440/480V 3 ~	60	36.0	38.0	63/50
	220V 3 ~	50/60	32.9	35.0	100
Steam or Non heated	220-240V 3 ~	50/60	-	4.5	20
	380-480V 3 ~	50/60	-	4.5	10

Water, steam and air connection			W4400H
Water valves	DN		25
Rec. water pressure	kPa		200-600
Functioning limits for water valve	kPa		50-1000
Capacity at 300 kPa	l/min		110
Drain valve	∅ mm		110
Draining capacity	l/min		400
Steam valve	DN		20
Rec. steam pressure	kPa		300-600
Functioning limits for steam valve	kPa		50-800
Compressed air	DN		6
Air pressure	kPa		500-700
Air consumption	l/h		20
Five-compartment detergent injector	DN		20
Floor requirements			
Frequency of the dynamic force	Hz		13.8
Floor load at max extraction	kN		15.8 ± 1.2
Sound levels			
Sound pressure level*	dB(A)		75
With insulation	dB(A)		< 70
Heat emission			
% of installed power, max			5
Shipping data**			
Shipping volume	net, kg		1200
	crated, kg		1300
	m ³		5.33

* A-weighted emission sound pressure level at workingstations.

** Average data. Crated weight/shipping volume depends on configuration. Please contact logistics for exact measures.

Dimensions in mm	W4400H
A Width	1325
B Depth	1450
C Height std/tilt+IWS	1975/2015
C Height, low foot	1890
D std/tilt+IWS	870/910
Ea	300
Eb	210
F std/tilt+IWS	1815/1865
G	270
H std/tilt+IWS	780/820
I std/tilt+IWS	380/420
K	435
L	425
M	525
N	660
O	2235
P	950
R	830
S	370
T	2205
U	1140
V	345

1	Control panel
2	Door opening \varnothing 535
3a	Five-compartment detergent box, front (optional)
3b	Five-compartment detergent box, right hand side (optional)
4	Cold water connection
5	Hot water connection
6	Third water connection (optional)
7	Steam connection
8	Drain
9	Electrical connection
10	Compressed air connection
11	External liquid detergent connections, 6 pcs \varnothing 10 mm, 1 pc \varnothing 16 mm and 1 pc \varnothing 20 mm
12	Water connection, detergent injector (optional) 3/4"

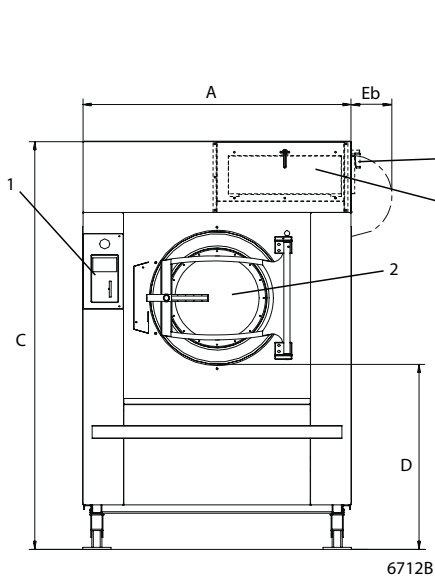

Front

6712B

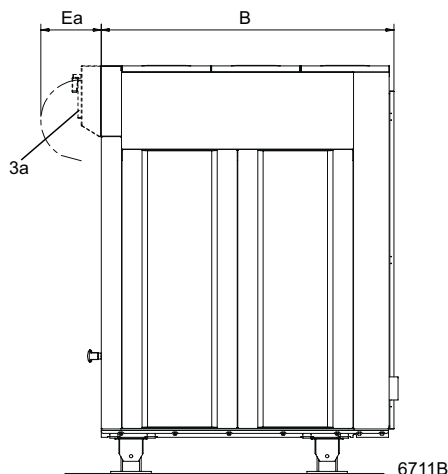

Right side

6711B

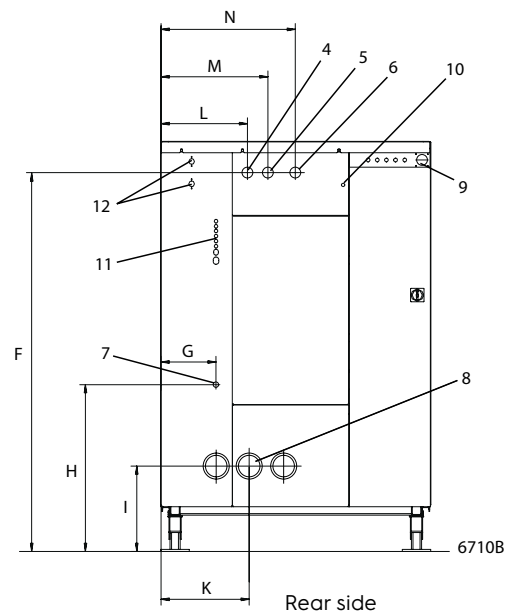

Rear side

6710B

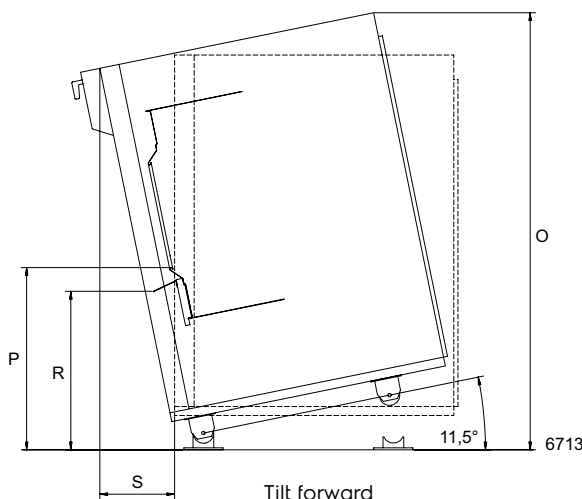

Tilt forward

6713

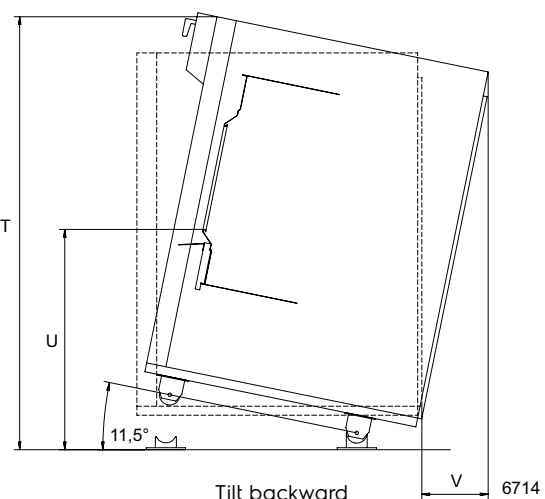

Tilt backward

6714

Options

- Front mounted loading hopper - easy loading from "sling-bag" system. Manually operated.
- Backwards and forwards tilting - backwards tilting can be used in conjunction with input wheel or other loading system.
- Forward tilting with drum reversal - makes unloading into a trolley easy.
- Noise/heat insulation - reduces airborne noise to less than 70 dB(A).
- Test tap with level tube - allows you to take samples from the wash solution.
- Water/wash solution recovery system - two drain valves allow you to recover rinse water and re-use it in the wash.
- Five-compartment detergent box. (5 x 1 litre) on right hand side or front
- Water inlet via pump - additional water inlet for water via pump from recovery system.
- Third water valve - electrically-controlled water valve for hard water.
- Steam connection components.
- Connection components for 2 water connections.
- Connection components for 3 water connections.
- Pump inlet connection components. Recovery
- IS - Integrated Saving.
- Combined steam and electrical heating - allows you to switch between electricity and steam.
- Connection to intelligent detergent system (DMIS)
- Large water valves (DN 32 / 1 1/4" BSP)
- Kit for connection to CMIS (Certus Management Information Systems) network. CMIS provides vital statistics, error codes, maintenance intervals, process receipt, etc.

Accessory

- WPM PC program. Allows the creation of wash programs on a PC and their transference to the machine via a memory card.



CMIS can be fitted to washer extractors with Clarus Control, tumble dryers with Selecta Control and ironers with electronic control system. All you need to access and view the statistical feedback is a normal PC.