

# Washer extractor

## W4850H

### Features and benefits

- Clarus Control<sup>®</sup> – programmable microprocessor with 9 fixed and up to 192 programs to allow free programming
- High extraction for efficient dewatering
- Frequency-controlled motor for optimal washing
- Supplied with 8 + 5 signals for liquid detergents
- Eight connections for liquid detergents
- Large door opening for easy loading and unloading
- All critical parts made from stainless steel to provide a high level of corrosion resistance
- Powder painted galvanised steel side panels
- Bearing seals lubricated with oil to ensure a long service life. Empty container alarm
- Direct steam heating.
- Low noise level for pleasant working environment
- Designed for easy servicing and maintenance

### Main options

- Forward or forward/backward tilting with full reversing function
- Noise/heat insulation
- Test tap with level tube
- Two drain valves for recovering water/wash solution
- Five-compartment detergent box for powder detergent (located at the front or on the right hand side of the machine)
- Third water valve
- Large water valves
- IS - Integrated Saving
- Connection for intelligent detergent system (DMIS)
- Connection to CMIS



Images shown are a representation of the product only and variations may occur.

Main specifications		W4850H
Max. capacity	kg/lb	90/200
Drum, volume	litre	850
diameter	ø mm	1220
Extraction	rpm	720
G-factor		350
Heating alternatives	steam	x
	non-heated	x
	electricity	-
<b>Consumption data "Normal 60°C" *</b>		
Total time (cold+hot/cold)	min	45/50
Water consumption (cold/hot)	litre	713/125
Energy consumption (motor/heating)	kWh	2.3/-
Steam consumption (cold/hot)	kg	10
Steam consumption (cold)	kg	19

\* Water temperature 15°C cold water and 65°C hot water.

Electrical connections					
Heating alternative	Main voltage		Heating power kW	Total power kW	Recommended fuse A
		Hz			
Steam or	220-240V 3 ~	50/60	-	6.3	25
Non heated	380-480V 3 ~	50/60	-	6.3	16

Water, steam and air connections			W4850H
Water valves	DN		32
Rec. Water pressure	kPa		200-600
Function limits for water valve	kPa		50-1000
Capacity at 300 kPa	l/min		150
Drain valve	∅ mm		110
Draining capacity	l/min		400
Steam valve	DN		32
Rec. Steam pressure	kPa		300-600
Function limits for steam valve	kPa		50-800
Compressed air	DN		6
Air pressure	kPa		500-700
Air consumption	l/h		20
Five-compartment detergent injector	DN		20
Floor requirements			
Frequency of the dynamic force	Hz		12.0
Floor load at max extraction	kN		25.9 ± 1.5
Sound levels			
Sound pressure level*	dB(A)		73
With insulation	dB(A)		< 70
Heat emission			
% of installed power, max 90°			6.7
Shipping data**			
Shipping volume	net, kg		2200
	m <sup>3</sup>		7.6

\* A-weighted emission sound pressure level at workingstations.

\*\* Average data. Crated weight/shipping volume depends on configuration. Please contact logistics for exact measures.

Dimensions in mm	W4850H
A Width	1640
B Depth	1635
C Height std/tilt+IWS	2190/2230
D std/tilt+IWS	955/995
Ea	300
Eb	380
F std/tilt+IWS	2095/2135
G	1070
H	830
I	635
K	445
L	1140
M std/tilt+IWS	1620/1660
N std/tilt+IWS	395/435
O	820
P	2410
R	1175
S	2480
T	960
U	285
V	400

- 1 Control panel
- 2 Door opening  $\varnothing$  700 mm
- 3a Five-compartment detergent box, front (optional)
- 3b Five-compartment detergent box, right hand side (optional)
- 4 Cold water connection
- 5 Hot water connection
- 6 Third water connection (optional)
- 7 Steam connection
- 8 Drain
- 9 Electrical connection
- 10 Compressed air connection
- 11 External liquid detergent injector, 6 pcs  $\varnothing$  10, 1 pc  $\varnothing$  16 and 1 pc  $\varnothing$  20
- 12 Water connection, detergent injector (optional)

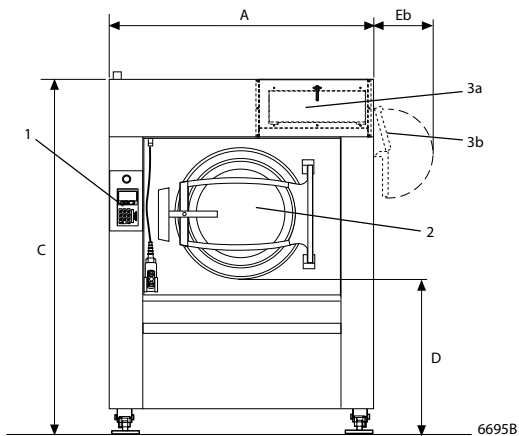

Front

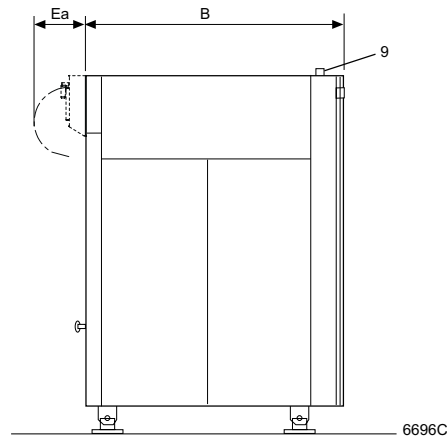

Right side

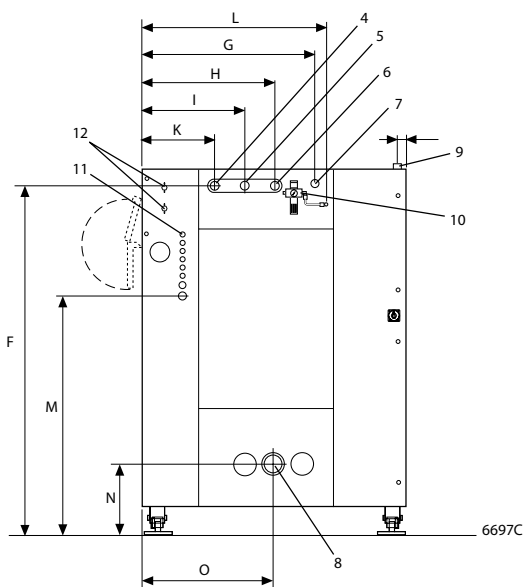

Rear side

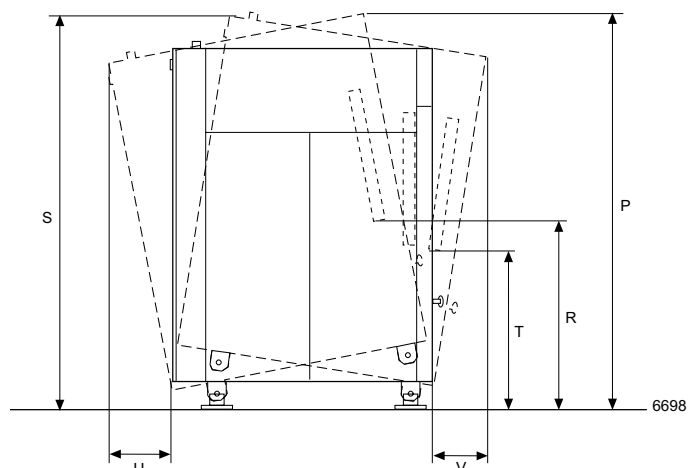

The movement when tilting

### Options

- Forward or forward/backward tilting with drum reversal – makes unloading into a trolley easy.
- Noise/heat insulation – reduces airborne noise to less than 70 dB(A).
- Test tap with level tube – allows you to take samples from the wash solution.
- Water/wash solution recovery system – two drain valves allow you to recover rinse water and re-use it in the wash.
- Five-compartment detergent box  
Option 1, (5x1 litre), located on front of the machine.  
Option 2, (5x2 litres), located on right hand side of the machine.
- Water inlet via pump – additional water inlet for water via pump from recovery system.
- Third water valve – electrically-controlled water valve for hard water.
- Steam connection components.
- Connection components for 2 water connections.
- Connection components for 3 water connections.
- Pump inlet connection components. Recovery
- IS – Integrated Saving
- Connection for intelligent detergent system (DMIS).
- Large water valves (DN 50 / 2" BSP) (DN 40 / 1 1/2" BSP).
- May be included in a hands-off system.
- Kit for connection to CMIS (Certus Management Information Systems) network.

### Accessory

- WPM PC program. Allows the creation of wash programs on a PC and their transference to the machine via a memory card.



CMIS can be fitted to washer extractors with Clarus Control, tumble dryers with Selecta Control and ironers with electronic control system. All you need to access and view the statistical feedback is a normal PC.